

Basic Four[®]
Installation Instructions
System 610/730

BFSID 8032 A

The information contained herein is proprietary to and considered a trade secret of Management Assistance Inc.

All rights reserved. No part of this publication may be reproduced, recorded or stored in a retrieval system, or transmitted, in any form or by any means, whether electronic, mechanical, photographic, or otherwise, without prior written permission of the Basic Four Information Systems Division of Management Assistance Inc.

All Rights Reserved

BFISD 8032 A

Copyright © 1981 by Management Assistance Inc.

All specifications are subject to change without notice.
Basic Four and MAI are registered trademarks of Management Assistance Inc.

Printed in the United States of America

Basic Four Information Systems Division/Management Assistance Inc.
14101 Myford Road, Tustin, California 92680/(714) 731-5100

Page	Title
1	Scope
1	System Concept
1	System Architecture
2	System Packaging and Cabling
2	Unpacking Instructions
4	Disc Drive
4	Preinstallation Checks
4	AC Power Requirements
8	Environmental Considerations
8	Temperature
8	Humidity
8	Static Electricity
8	Space Considerations
15	System Installation
15	System Placement
15	Central Cabinet Assembly PCB Location
15	CPU Chassis
15	Formatter Chassis
15	Switch Settings
15	Central Cabinet Assembly Switch Settings
16	VDT Switch Settings
17	Central Cabinet Assembly Power Supply Checks
17	Input Voltage Jumpers
19	DC Voltage Checks
21	System Cabling
21	Central Cabinet Assembly Inter-Board Cables
21	Central Cabinet Assembly Internal Cables
21	Disc Drive Cabling
25	VDT Cabling
25	Printer Cabling
25	Magnetic Tape Cartridge Drive Cabling
25	Additional Peripheral Device Cabling
26	Disc Drive Head Alignment Check
28	System Operational Checks

Page	Figures
1	1. System Architecture
3	2. System Interconnection Diagram
4	3. Disc Drive Out of Shipping Container
5	4. Shipping Bolt and Rear Cover Screws
6	5. Shipping Bracket
7	6. Disc Drive Shipping Block
7	7. Processor/Disc Drive 115 VAC Outlet Wiring 15 AMP Rating
7	8. Peripheral 115 VAC Outlet Wiring (U.S.A Color Code Shown)
9	9. Typical System 610/730 Floor Plan
16	10. CPU Switch Settings
17	11. 4- or 8-Port Controller Switch Settings
17	12. Central Cabinet Assembly Power Supply Tilted Against Stops
18	13. Input Voltage Jumper Wiring on TB3
19	14. TBI of Central Cabinet Assembly Power Supply
22	15. Disc Bus Cable Origination
22	16. Disc Bus Cable Termination
23	17. Disc Bus Interconnect Cable Origination
24	18. Disc Bus Interconnect Cable Termination
24	19. Disc Radial Cable Origination
25	20. Disc Radial Cable Termination
26	21. Magnetic Tape Cartridge Drive Cabling
27	22. Head Alignment Test Points
28	23. Ideal Dibit Pattern

Tables

2	1. System Configuration
10	2. Installation Specifications
16	3. CPU Switch Settings

Installation Instructions

Scope

The installation instructions will enable an experienced Service Engineer to properly install a System 610/730. Functional descriptions and detailed theory of operation are not included in these instructions.

The installation instructions describe the System 610/730 in terms of packaging, cabling, modularity, and expansion capability. The system architecture and system components are described to the extent needed to successfully accomplish the installation tasks.

The installation instructions assume the installation site has been prepared as described in the System 610/730 Physical Installation Planning Guide (BFC 5043).

System Concept

The System 610/730 is a disc based business system. A system can have a maximum of four disc drives, 16 VDTs, two matrix printers, and six memory modules. The Central Cabinet Assembly contains a 1300 series CPU chassis, disc formatter chassis, power supply, backup battery, and control panel.

System Architecture

System architecture is graphically depicted in Figure 1. Minimum and maximum configurations are shown in Table 1.

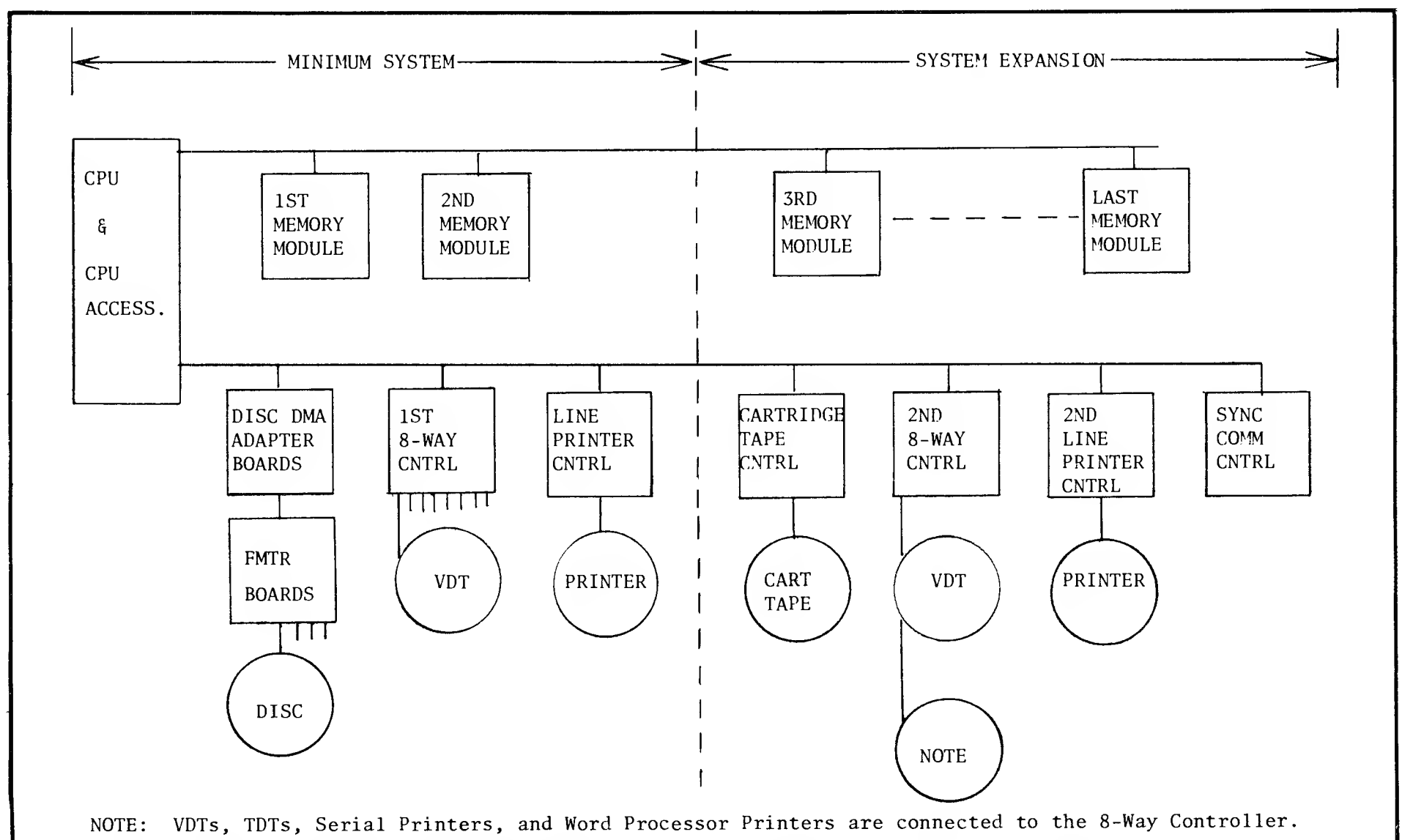

Figure 1. System Architecture

Installation Instructions

Table 1. System Configuration

Component	610 Min. System	730 Min. System	610/730 Max. System
CPU	1	1	1
Memory Capacity	64K bytes	96K bytes	128K/256K bytes
Disc Drives	1	2	4 *
Disc Capacity	35 Mbytes	150 Mbytes	300 Mbytes
VDT	1	4	16 **
Printer	1	1 **	
Tape Cartridge	1	∅	1 *
Mag Tape	∅	∅	2
Sync. Comm	∅	∅	1
TDT	∅	∅	2 **
Word Processor Printer	∅	∅	2 **
VDT Desk	1	4	16

*Model 2530 disc drive has 47 Mbytes maxformatted capacity and the Model 2580 has 75 Mbytes maxformatted capacity. Drive capacity can be limited by software to smaller values. Minimum system can be either two disc drives or one disc and one tape cartridge.

**Maximum number of VDTs, TDTs, Serial Matrix Printers, and Word Processor Printers (or combination of) cannot exceed 32. A maximum of 2 parallel interface printers are allowed.

NOTE: System Configuration Specifications are subject to change without notice.

System Packaging and Cabling

The Central Cabinet Assembly is a desk-height enclosure containing the CPU chassis, formatter chassis, power supply, and battery backup supply. The major items external to the Central Cabinet Assembly are the disc drive(s), VDT(s), printer(s), and magnetic, cartridge tape drive.

Cabling internal to the Central Cabinet Assembly and cabling between the Central Cabinet Assembly and peripheral devices is shown in Figure 2.

Unpacking Instructions

Use the following procedure to unpack the System 610/730 and peripherals from their shipping containers.

Prior to unpacking the shipping containers, carefully inspect them for signs of damage that may have occurred in shipment. Any damage must be noted on the carrier's shipping form. NOTIFY the Branch and/or Dealer Office(s) of any shortage or damage immediately so that corrective action can be taken.

Carefully remove the Central Cabinet Assembly, disc drive unit(s), printer(s), VDT(s), and cartridge tape drive (if present) from their respective shipping containers. Save all shipping containers and packing materials in the event that reshipment of the equipment is required at a later date.

Ensure that the system is complete. Compare the items sent with the Shipping List. If it is found that the system is incomplete, make a list of the missing items and notify the Branch and/or Dealer office(s).

Visually inspect all items for shipping damage. Pay particular attention to inspection of cables and connectors for pinched wires and/or poor electrical connections. Report any damaged parts to the Branch and/or Dealer office(s).

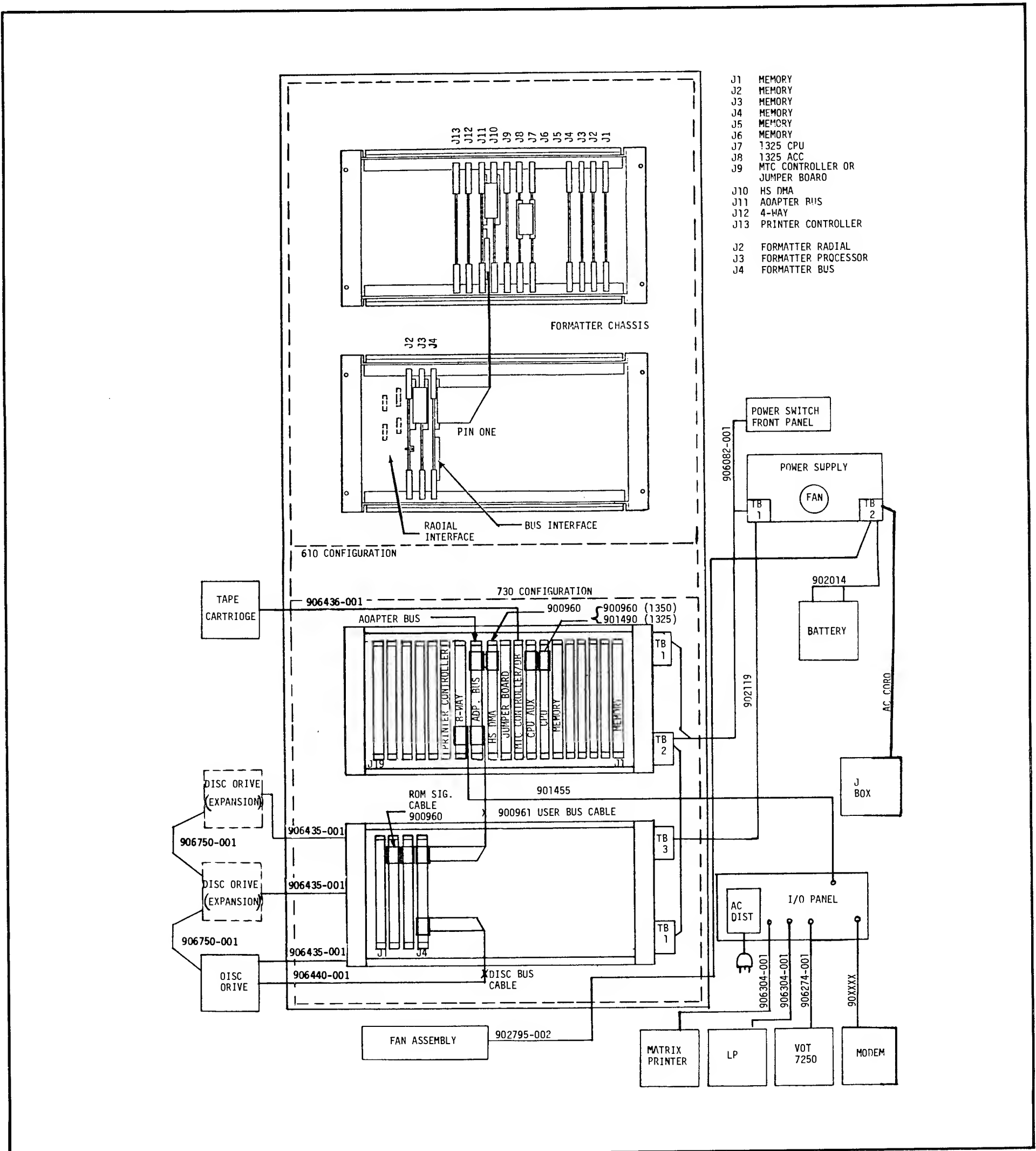

Figure 2. System Interconnection Diagram

Disc Drive

Figure 3 shows the disc drive after it has been removed from its shipping container and pallet. The instructions on the red WARNING label are further explained here.



Figure 3. Disc Drive Out of Shipping Container

Preinstallation Checks

AC Power Requirements

The System 610/730 requires input power that is well regulated and free of line transients. Reduced line voltage and common transient conditions can cause many "no trouble found" system problems. It is absolutely necessary that the following input power requirements are met.

1. The AC power outlets supply 115 VAC/60 Hz (or 230 VAC/50 Hz) and are located so that power extension cords are not used.
2. The CPU and each disc drive are serviced by separate protected circuits which must be free of electrical disturbances.

3. The CPU and each disc drive should be protected by a 15 amp circuit breaker. All other devices may be connected to standard service outlets protected by 15 amp circuit breakers.
4. The AC line maintains its rated voltage $\pm 10\%$ and its frequency $\pm 0.2\%$.

CAUTION

Failure to follow these instructions will result in damage to the disc drive.

Shipping Bolt

A 3/8-inch Allen head shipping bolt is located in the center of the disc drive rear panel (see Figure 4). This bolt locks the deck casting to the frame assembly. Using a 5/16-inch Allen wrench, remove and store the bolt, lockwasher, and flat washer.

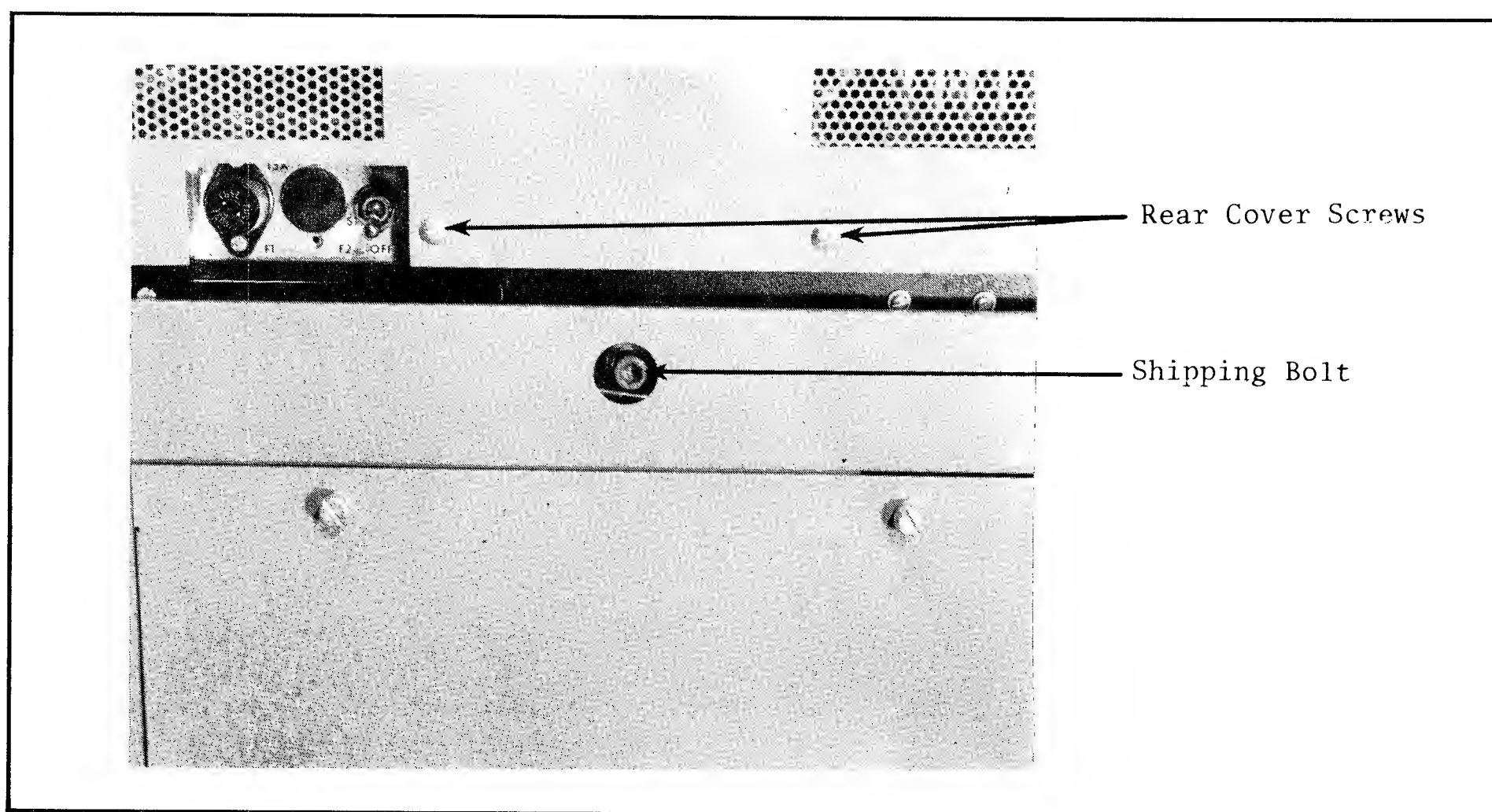

Figure 4. Shipping Bolt and Rear Cover Screws

Linear Motor Tape

The tape referred to on the red WARNING label is no longer used. A more efficient shipping bracket retains the read/write heads on the cam tower.

Installation Instructions

Shipping Bracket

Unlatch and open the pack area lid to reveal the shipping bracket inside the disc pack air shroud (see Figure 5). This bracket holds the read/write heads on their camming surfaces.

Remove the three screws designated in Figure 5 and carefully remove the shipping bracket. Store the shipping bracket for future use.

Reinstall the three screws in the locations from which they were removed.

Clean the pack area with a lint-free cloth, slightly dampened with clean water, and follow with a dry lint-free cloth. Be careful not to touch or jar the read/write heads.

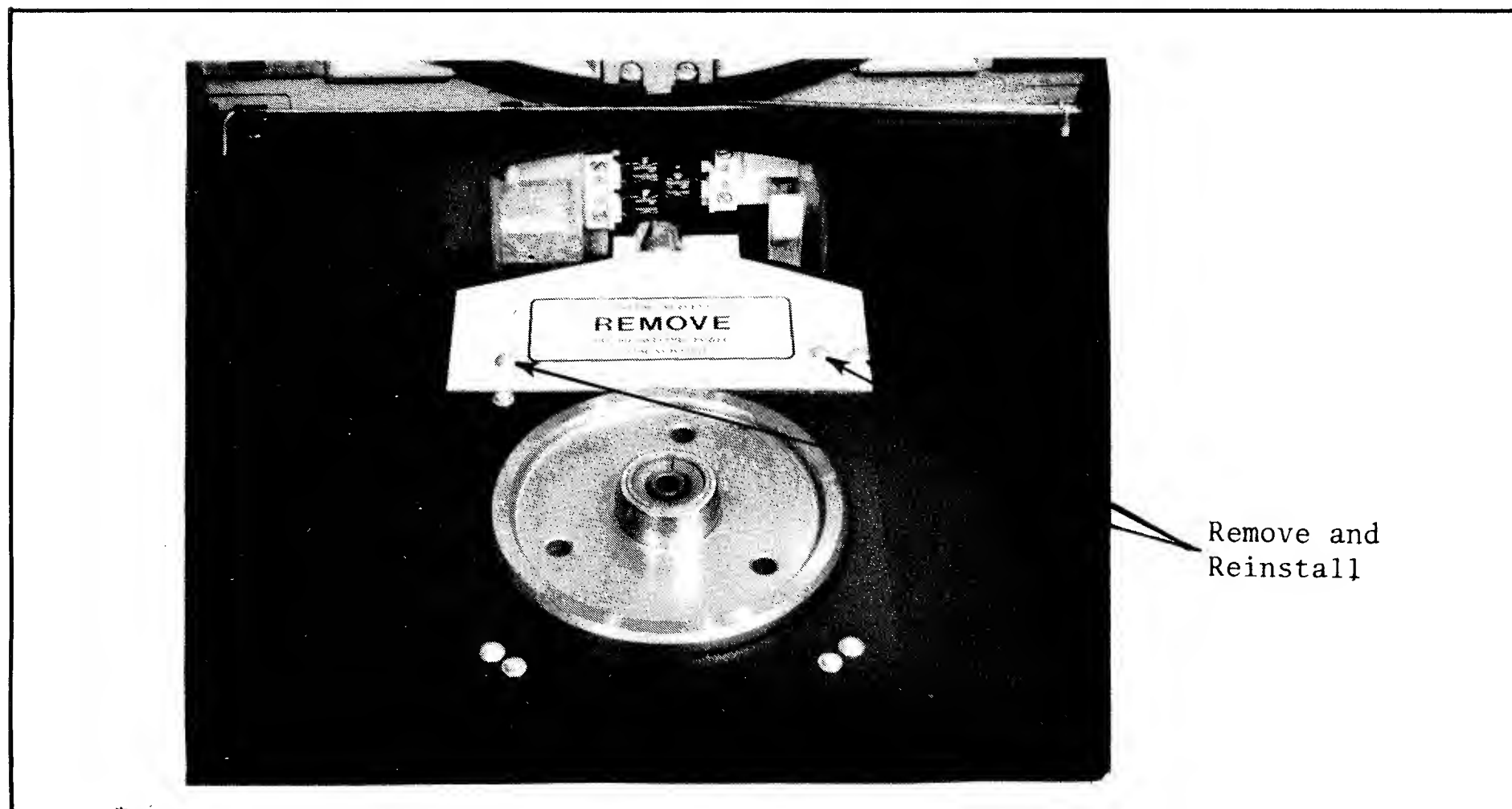

Figure 5. Shipping Bracket

Shipping Block

Remove the two Phillips head screws shown in Figure 4. Lift the rear cover from the disc drive being careful not to strike the card cage and power supply.

Remove the small wooden shipping block shown in Figure 6. It may be necessary to slightly move the linear motor housing to allow the block to be removed. Store the block with the bolt and bracket previously removed.

Carefully reinstall the rear cover and the two retaining screws.

Remove the red WARNING tag from the pack area lid and store for later use.

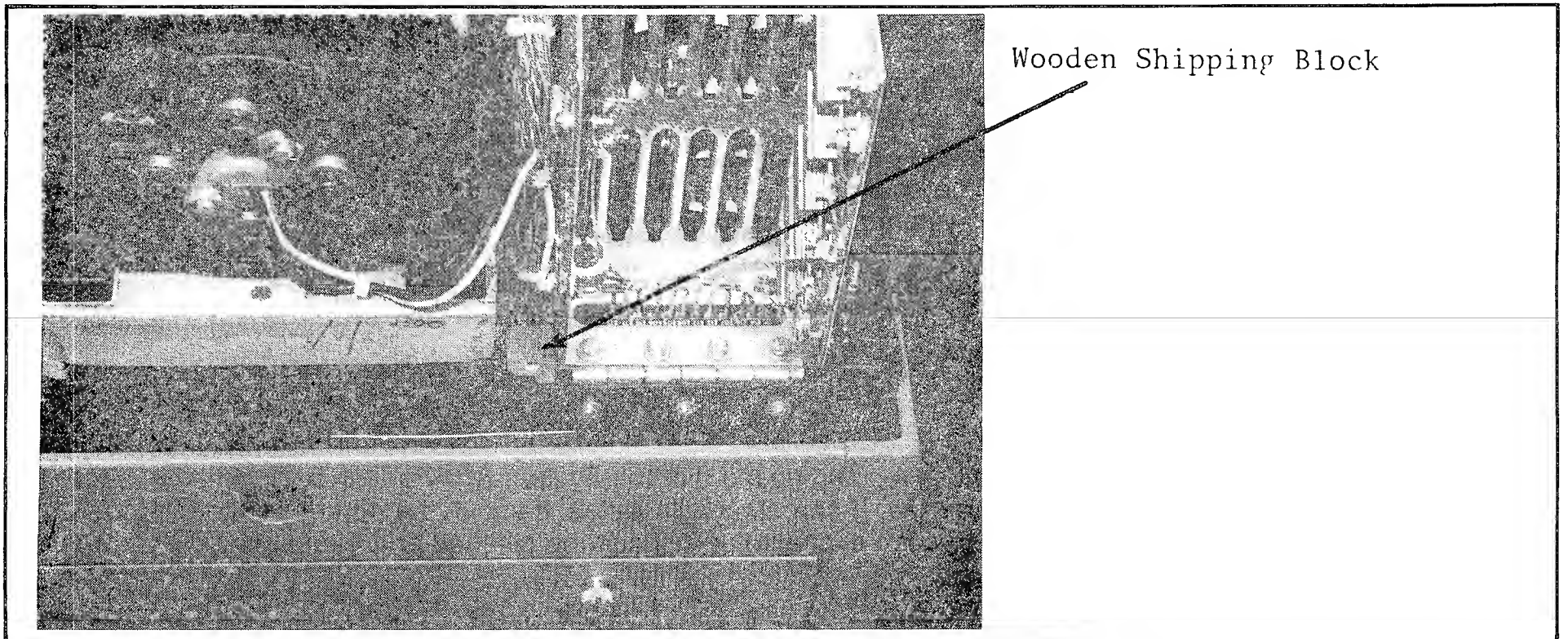

Figure 6. Disc Drive Shipping Block

The Central Cabinet Assembly and each disc drive have a 10-foot power cable with a Hubbell 4720 plug that requires a Hubbell 4700 receptacle (or equivalent) for use within the United States. (For international installations, see your Basic Four Representative to determine correct connections.) All other system peripherals can be connected to a standard 3-wire outlet. Verify that the AC outlets are wired as shown in Figures 7 and 8.

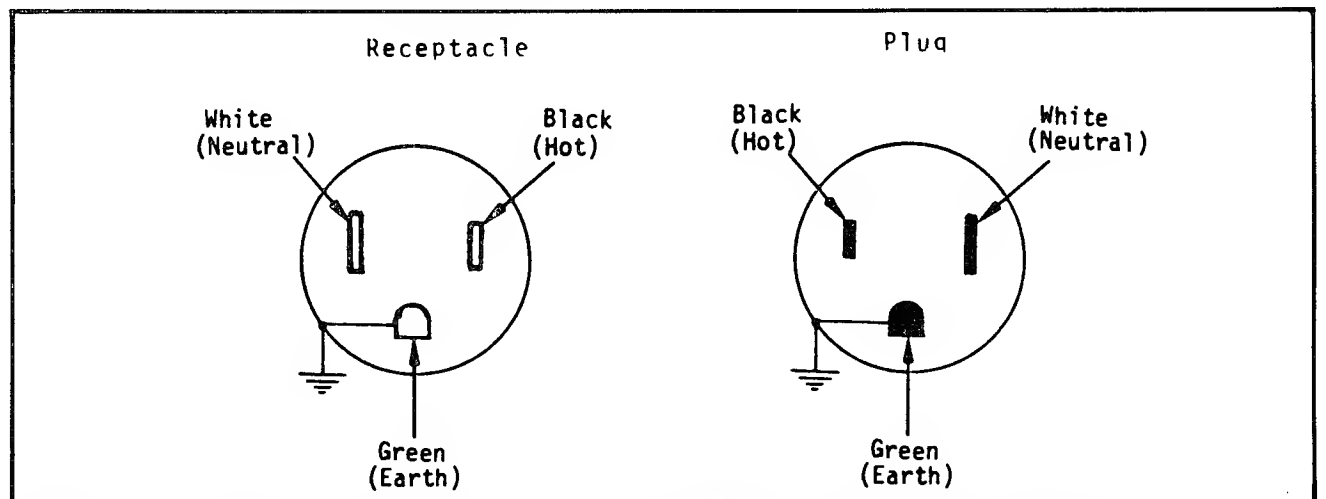

Figure 7. Processor/Disc Drive 115 VAC Outlet Wiring 15 AMP Rating

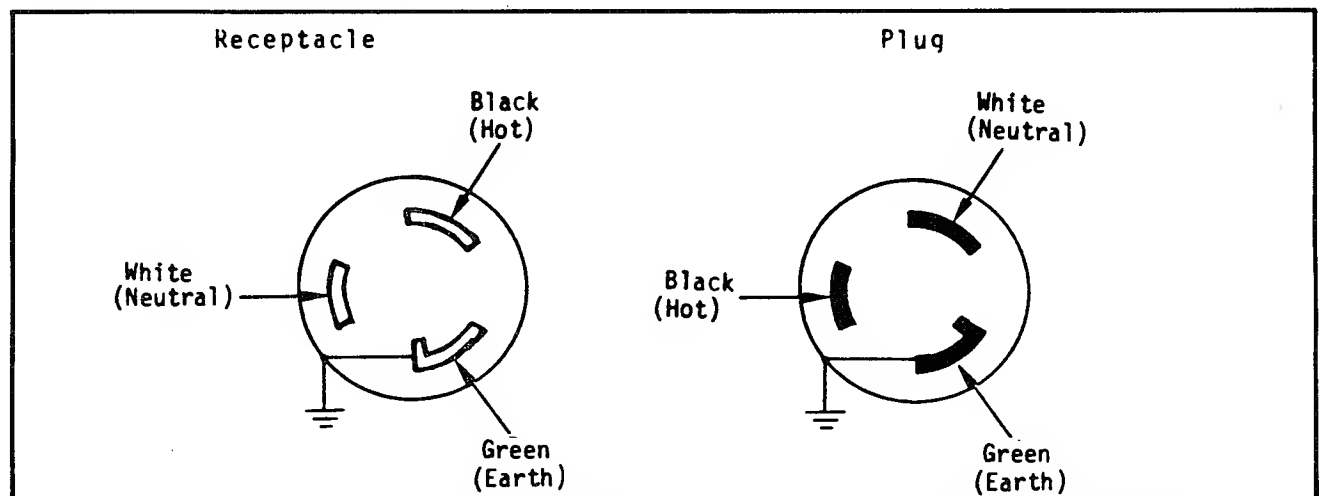

Figure 8. Peripheral 115 VAC Outlet Wiring (U.S.A Color Code Shown)

Installation Instructions

Environmental Considerations

Temperature

The recommended ambient operating temperature range for the System 610/730 is from 65°F to 80°F (18°C to 27°C). Readjustment of existing temperature controls or additional air conditioning may be required to maintain ambient temperature in this range. Operation outside this range can lead to system malfunctions.

Humidity

The recommended ambient operating humidity range for the System 610/730 is from 40 to 60 percent relative. Operation outside this range can cause static problems at low humidity and printer paper handling problems at high humidity.

Static Electricity

Certain types of carpeting, such as wool, tend to build up static electricity. It is therefore recommended that the System 610/730 not be installed in a carpeted area. If carpeting is installed, it should be of the non-static type (Brunslon is an example) or it should be cleaned and then sprayed with a non-static fluid.

Static discharges on or near the System 610/730 can cause system malfunctions.

Space Considerations

Operational requirements should determine the locations of the various system components in the computer area. Take into consideration signal cable lengths and the necessity of maintaining clearances between components for ease of servicing. A typical System 610/730 installation is shown in Figure 9.

The parameters that apply to system installation are listed in Table 2. These include dimensions, service clearances, weights, and other pertinent data.

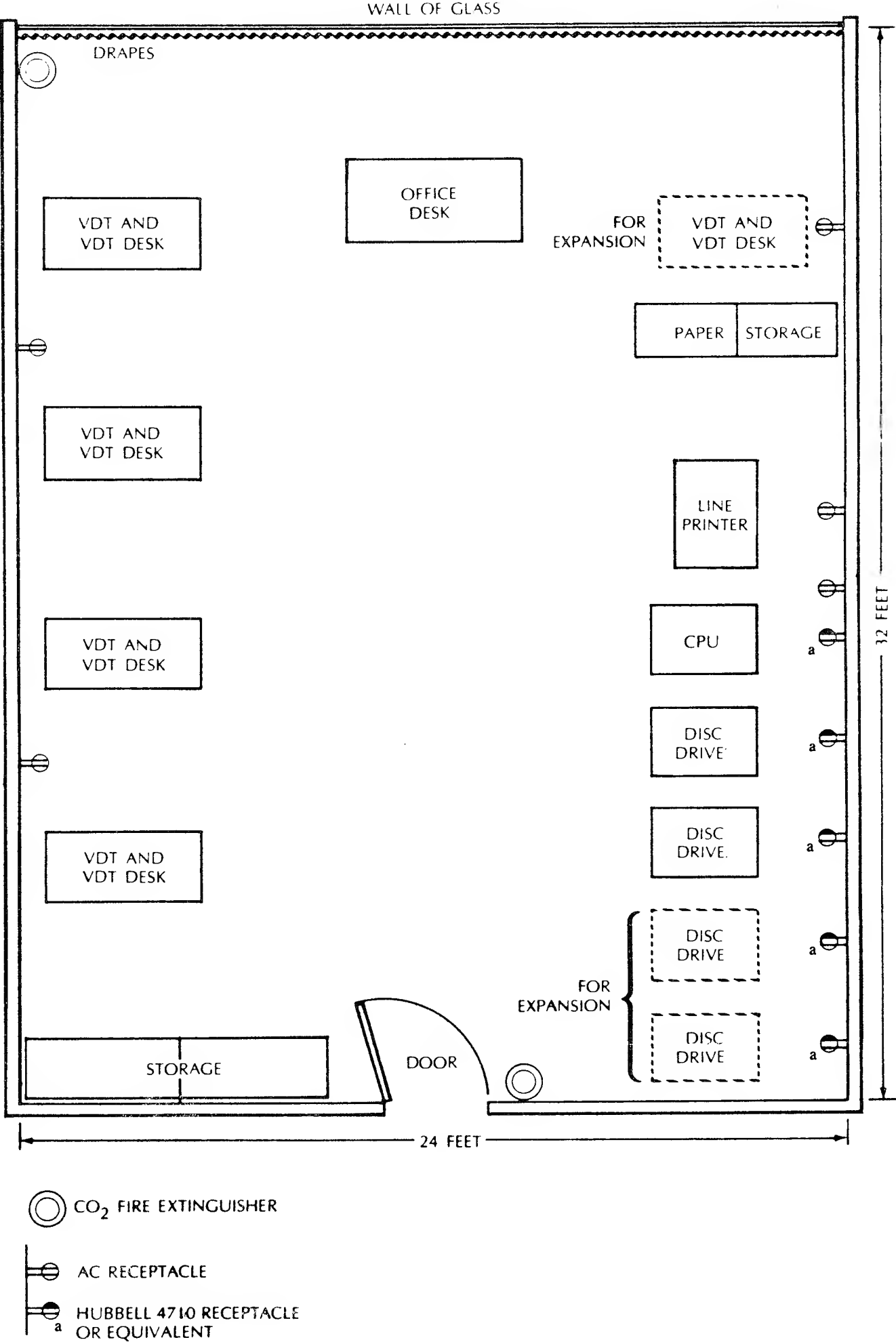

Figure 9. Typical System 610/730 Floor Plan

Table 2. Installation Specifications

Parameters	Characteristics
CPU Cabinet	
Dimensions	
Width	23.0 inches (58.0 cm)
Depth	33.5 inches (85.0 cm)
Height	30.0 inches (76.2 cm)
Service Clearances	
Front	36.0 inches (91.4 cm)
Rear	30.0 inches (76.2 cm)
Sides	18.0 inches (45.7 cm)
Weight	220 pounds (99.8 kg)
Electrical	
Voltage	115/230 VAC \pm 10%
Frequency	60/50 Hz
Current	11.9/5.9 A
Power	1, 265 VA
Environment	
Temperature	65°F - 80°F (18°C - 27°C)
humidity	40% - 60%
Heat Dissipation	4,300 BTU/Hour
Cable Length	
Power	10.0 feet (3.05 m)
Disc Drive	
Dimensions	
Width	19.0 inches (48.3 cm)
Depth	33.5 inches (85.0 cm)
Height	30.0 inches (76.2 cm)
Service Clearances	
Front	36.0 inches (91.4 cm)
Rear	30.0 inches (76.2 cm)
Sides	18.0 inches (45.7 cm)
Weight	240 pounds (109 kg)

Table 2. Installation Specifications (continued)

Parameters	Characteristics
Electrical	
Voltage	115/230 VAC ± 10%
Frequency	60/50 Hz
Current	7.5/3.8A
Power	1K VA (3K at start)
Environment	
Temperature	65°F - 80°F (18°C - 27°C)
Humidity	40% - 60%
Heat Dissipation	3,400 BTU/Hour
Cable Length	
Power	10.0 feet (3.05 m)
Signal	5.0 feet (1.52 m)
Character Printer (Model 3200 Series)	
Dimensions	
Width	26.0 inches (66.0 cm)
Depth	21.0 inches (53.3 cm)
Height	10.0 inches (25.4 cm)
Service Clearances	
Front	36.0 inches (91.2 cm)
Rear	30.0 inches (76.2 cm)
Sides	18.0 inches (45.7 cm)
Weight	65 pounds (29.5 kg)
Electrical	
Voltage	115/230 VAC ± 10%
Frequency	60/50 Hz
Current	5/2.5 A
Power	575 VA
Environment	
Temperature	65°F - 80°F (18°C - 27°C)
Humidity	40% - 60%
Heat Dissipation	1,955 BTU/Hour
Cable Length	
Power	8.0 feet (2.44 m)
Signal	15.0 feet (4.58 m)

Table 2. Installation Specifications (continued)

Parameters	Characteristics
Line Printer (Model 3510)	
Dimensions	
Width	30.0 inches (76.2 cm)
Depth	24.5 inches (62.2 cm)
Height	40.0 inches (101.6 cm)
Service Clearances	
Front	36.0 inches (91.4 cm)
Rear	30.0 inches (76.2 cm)
Sides	
Weight	210 pounds (95.3 kg)
Electrical	
Voltage	115/230 VAC \pm 10%
Frequency	60/50 Hz
Current	7/3.6 A
Power	550 VA
Environment	
Temperature	65°C - 80°F (18°C - 27°C)
Humidity	40% - 60%
Heat Dissipation	1, 870 BTU/Hour
Cable Length	
Power	10.0 feet (3.05 m)
Signal	15.0 feet (4.57 m)
Line Printer (Model 3600)	
Dimensions	
Width	33.0 inches (83.8 cm)
Depth	26.0 inches (66.0 cm)
Height	44.5 inches (113.0 cm)
Service Clearances	
Front	36.0 inches (91.4 cm)
Rear	30.0 inches (76.2 cm)
Sides	18.0 inches (45.7 cm)
Weight	370 pounds (167.8 kg)

Table 2. Installation Specifications (continued)

Parameters	Characteristics
<p>Electrical</p> <p>Voltage Frequency Current Power</p>	<p>115/230 VAC \pm 10% 60/50 HZ 6/3.1 A 680 VA</p>
<p>Environment</p> <p>Temperature Humidity Heat Dissipation</p>	<p>65°F - 80°F (18°C - 27°C) 40% - 60% 2, 312 BTU/Hour</p>
<p>Cable Length</p> <p>Power Signal</p>	<p>12.0 feet (3.66 m) 15.0 feet (4.57 m)</p>
Cartridge Tape Drive	
<p>Dimensions</p> <p>Width Depth Height</p>	<p>13.5 inches (34.3 cm) 12.0 inches (30.5 cm) 6.0 inches (15.2 cm)</p>
<p>Weight</p>	<p>16 pounds (7.3 kg)</p>
<p>Electrical</p> <p>Voltage Frequency Current Power</p>	<p>115/230 VAC \pm 10% 60/50 Hz 1.5/0.76 A 172 VA</p>
<p>Environment</p> <p>Temperature Humidity Heat Dissipation</p>	<p>65°F - 80°F (18°C - 27°C) 40% - 60% 585 BTU/Hour</p>
<p>Cable Length</p> <p>Power Signal</p>	<p>10 feet (3.05 m) 6 feet (1.83 m)</p>

Table 2. Installation Specifications (continued)

Parameters	Characteristics
VDT	
Dimensions	
Width	18.0 inches (45.7 cm)
Depth	21.0 inches (53.3 cm)
Height	12.5 inches (31.8 cm)
Service Clearances	
Front	36.0 inches (91.4 cm)
Rear	12.0 inches (30.5 cm)
Sides	6.0 inches (15.2 cm)
Weight	45 pounds (20.4 kg)
Electrical	
Voltage	115/230 VAC \pm 10%
Frequency	60/50 Hz
Current	1.1/0.56 A
Power	230 VA
Environment	
Temperature	65°F - 80°F (18°C - 27°C)
Humidity	40% - 60%
Heat Dissipation	782 BTU/Hour
Cable Length	
Power	7.0 feet (2.13 m)
Signal	25.0 feet (7.62 m)
VDT Table	
Dimensions	
Width	54.0 inches (137.0 cm)
Depth	36.0 inches (91.4 cm)
Height	28.0 inches (71.1 cm)
Service Clearances	
Front	54.0 inches (137.0 cm)
Rear	36.0 inches (91.4 cm)
Sides	28.0 inches (71.1 cm)
Weight	105 pounds (47.7 kg)

System Installation

CAUTION

It is important to follow the installation procedure in the order given. Failure to do so may result in improper operation or, in extreme instances, system damage.

The System 610/730 is given a thorough functional test before being shipped. Installation consists primarily of placing the system components in their proper location; verifying such items as circuit board location and switch settings; checking system DC voltages; cabling system components together, and performing an operational system checkout.

System Placement

Place all major system components; e.g., Central Cabinet Assembly, disc drive(s), printer(s), and VDT(s) in their proper location. Ensure that the system layout conforms to the System 610/730 Physical Installation Planning Guide. Be certain adequate clearance is provided for maintenance access (refer to Table 2).

**Central Cabinet Assembly
PCB Location**

CPU Chassis

Partially extract each PCB from the CPU chassis, verify that it is in the proper slot, and reinsert firmly (see Figure 2 for PCB location). The correct PCB locations are repeated here for convenience.

J1 through J6	Memory
J7 and J8	CPU and CPU ACC
J9	Cartridge Tape Controller or Jumper Board
J10	Jumper Board
J11	High-Speed DMA Controller (Trident)
J12	Adapter Bus (Trident)
J13	Terminal Controller
J14 through J19	Other I/O Controllers

Formatter Chassis

Partially extract each PCB from the formatter chassis, verify that it is in the proper slot, and reinsert firmly (see Figure 2 for PCB location). The correct PCB locations are repeated here for convenience.

J1	Not Used
J2	Formatter Radial
J3	Formatter Processor
J4	Formatter Buss

Switch Settings

**Central Cabinet Assembly
Switch Settings**

To load the Basic Operating System Software (BOSS), verify that the switches on the CPU board are set as shown in Figure 10.

Switch settings for VDT boot and cartridge tape load are listed in Table 3.

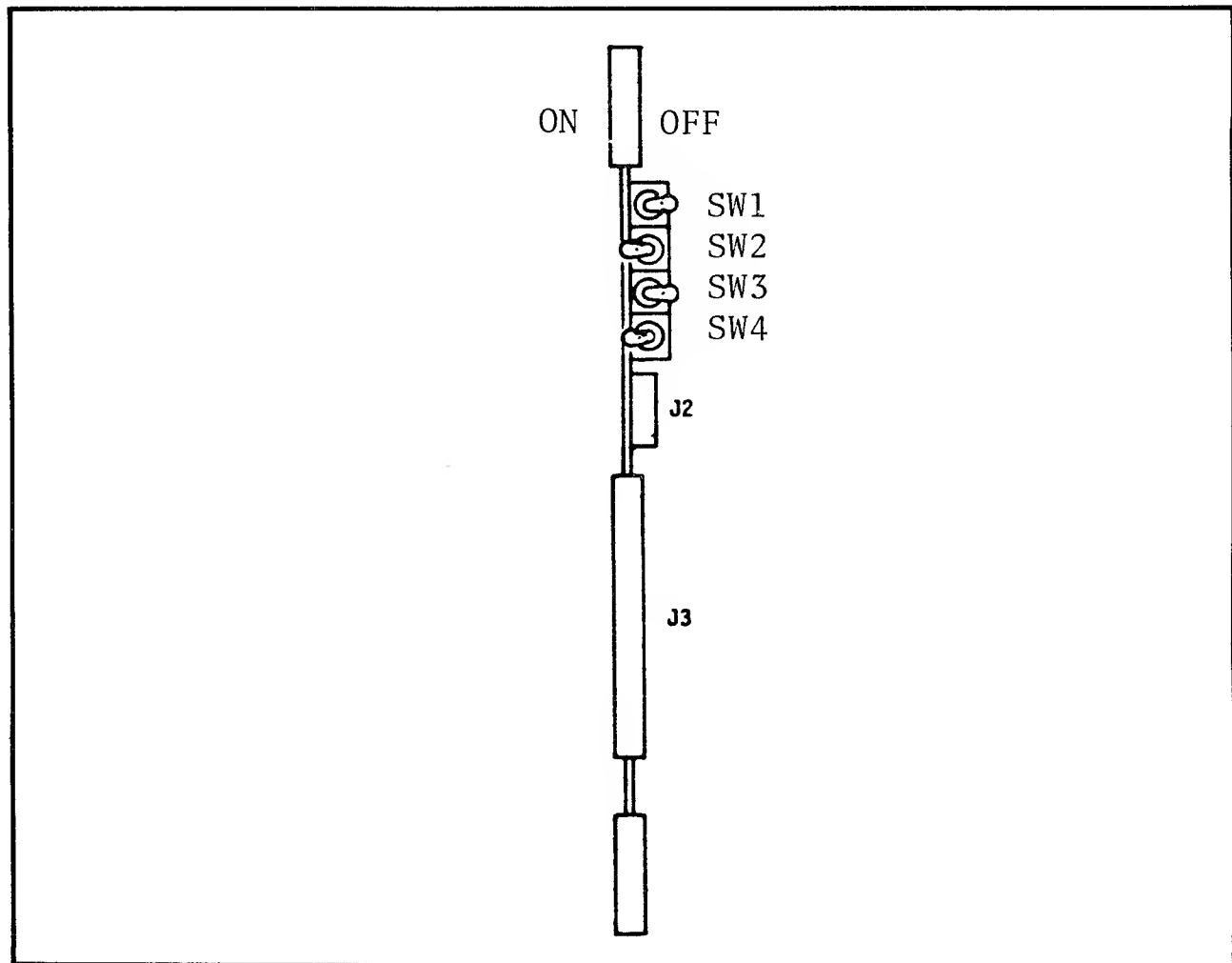

Figure 10. CPU Switch Settings

Table 3. CPU Switch Settings

Operation	SW1	SW2	SW3	SW4
VDT Boot	On	Off	Off	On
Load From Disc Drive	Off	On	Off	On
Load From Cartridge Tape Drive	On	On	On	On

Verify that the switches on the VDT 4- or 8-port controller board(s) are set as shown in Figure 11 (this configuration shows the VDT operating at 9,600 baud).

Verify that switch S1 on each memory module is set to address a contiguous block of memory beginning at location 0. Correct switch settings are depicted on a chart on each memory module.

VDT switch Settings

Verify that the baud rate switch on the rear of each VDT is set to 9,600 and the mode switch on the rear of each VDT is set to full-duplex.

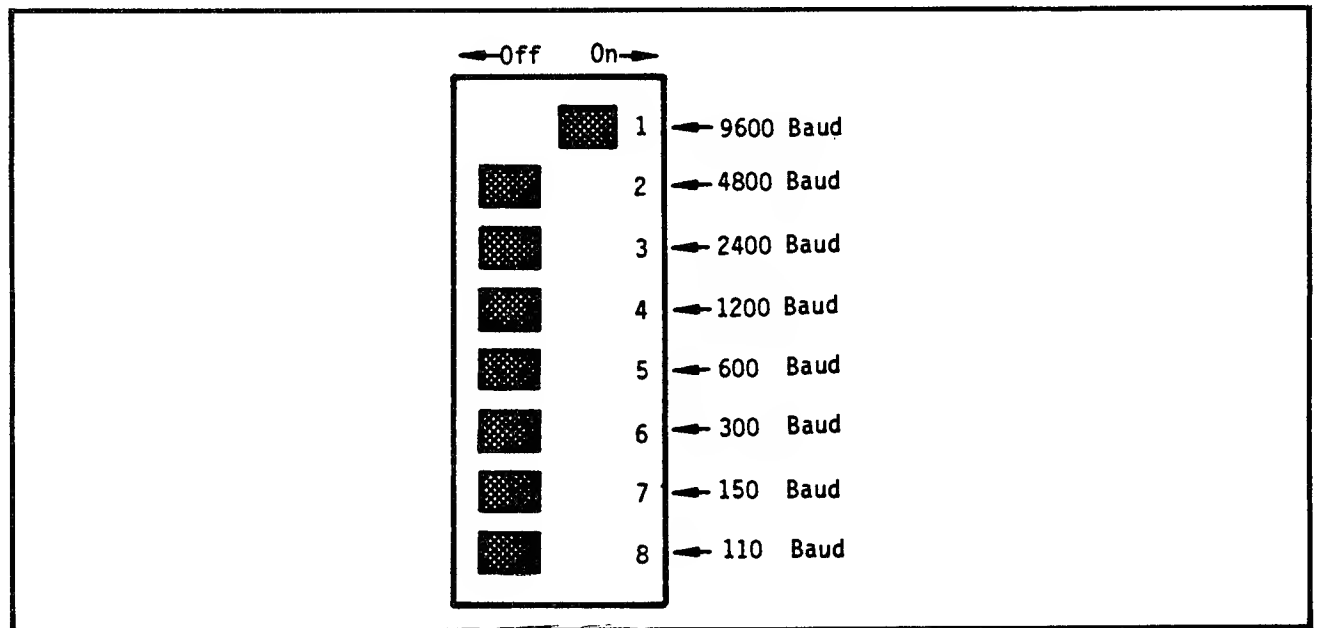

Figure 11. 4- or 8-Port Controller Switch Settings

**Central Cabinet Assembly
Power Supply Checks**

WARNING

The following checks involve possible exposure to lethal voltages. Ensure that the Central Cabinet Assembly power cord is disconnected from its service outlet before proceeding.

Input Voltage Jumpers

Release the springed screws and tilt the Central Cabinet Assembly power supply outward until it rests against its stops (see Figure 12). Remove the rear cover of the power supply and locate the Transformer Terminal board (TB3).

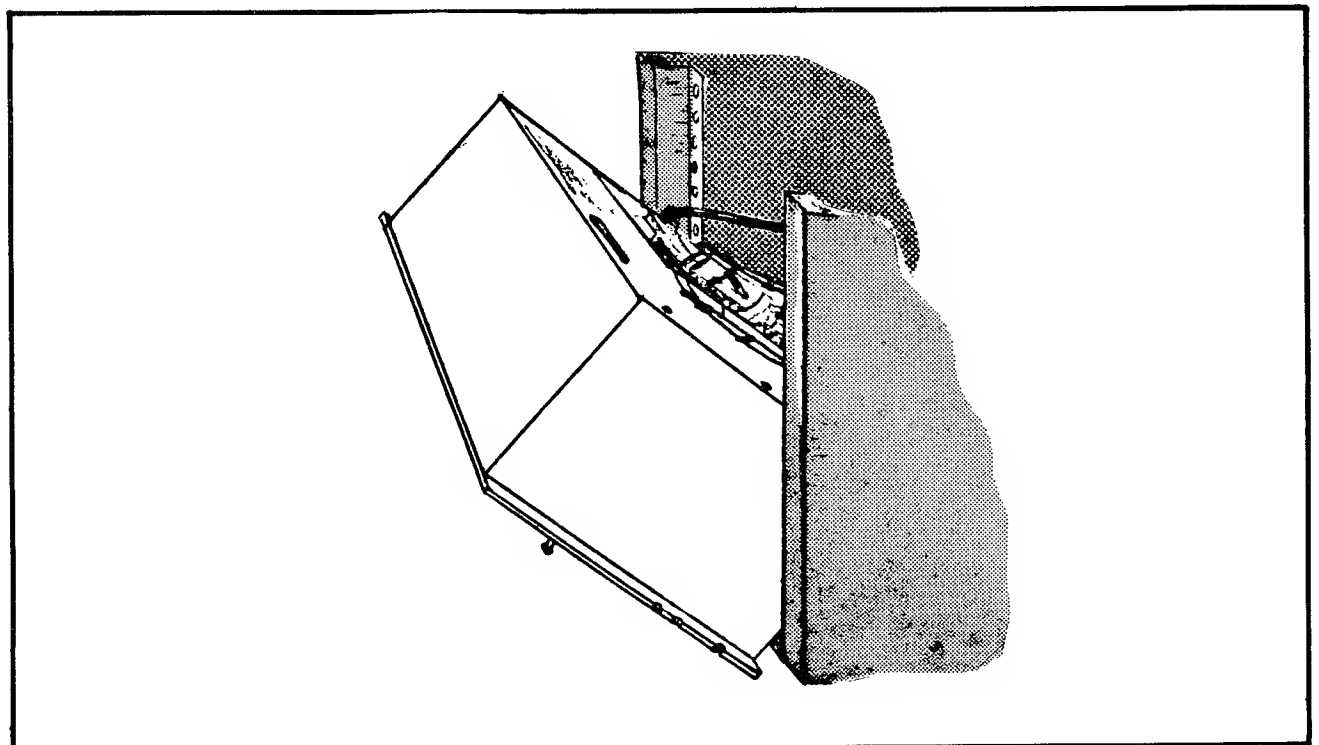

Figure 12. Central Cabinet Assembly Power Supply Tilted Against Stops

Ensure that the leads and jumpers on TB3 are correct for the nominal input line voltage. Correct wiring for common values of input voltage is shown in Figure 13.

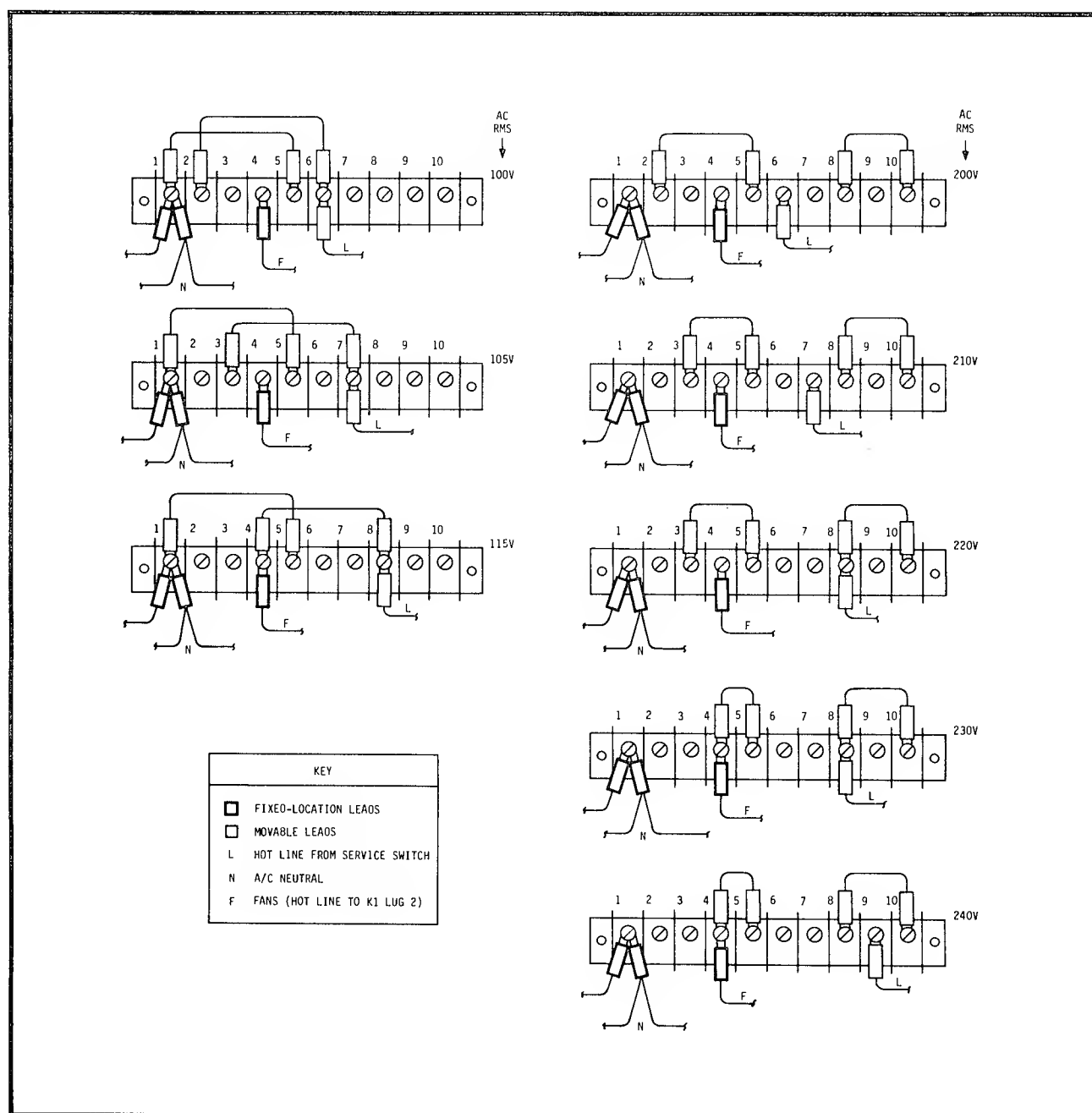

Figure 13. Input Voltage Jumper Wiring on TB3

NOTE

“Nominal” line voltage is the value under normal conditions. The power supply operates within a $\pm 10\%$ change in line voltage.

After making all voltage checks, reinstall the rear cover of the Central Cabinet Assembly power supply.

DC Voltage Checks

Connect the Central Cabinet Assembly AC service plug to the appropriate wall outlet and turn the power supply service switch on.

Locate TBI on the rear of the power supply (see Figure 14). Using terminals 6, 7, or 8 as a COMMON reference, measure the DC voltages at terminals 1, 2, 3, 4, 9, 10, and 11 with a digital multimeter. Appropriate adjustments are located above TBI and are so stenciled on the power supply cover. The DC voltages are regulated $\pm 2\%$.

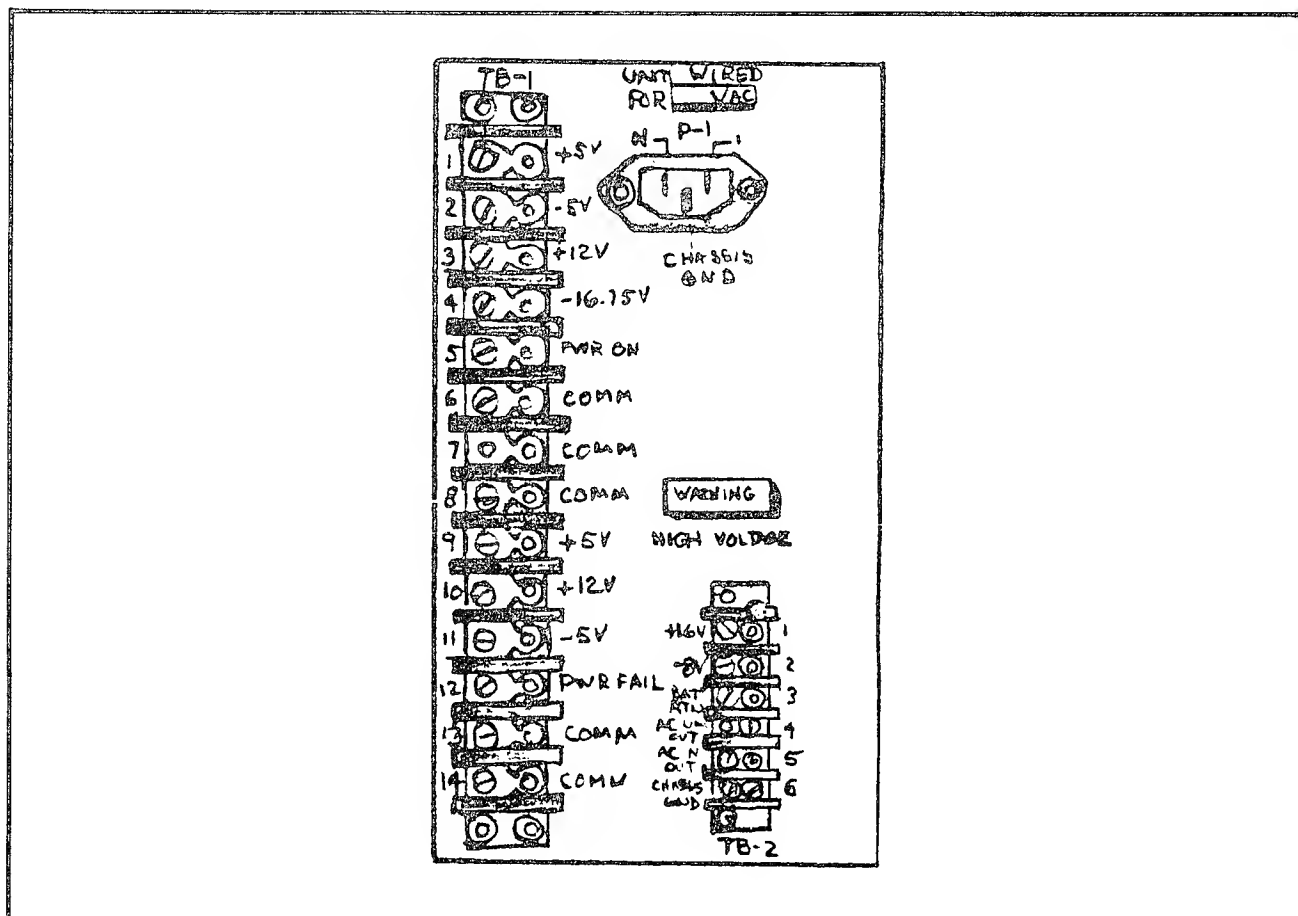

Figure 14. TBI of Central Cabinet Assembly Power Supply

System Cabling

Central Cabinet Assembly Inter-Board Cables

Check that the following cables are correctly routed and properly connected and seated.

Cable	From	To
P/N 901490 CPU Jumper Ribbon (Cable)	J2 on front of CPU Accessory Board	J3 on front of CPU Board
or		
P/N 900960 CPU Jumper Ribbon (Cable)		
P/N 900960 Disc Adapter Jumper Ribbon (Cable)	J2 on front of Disc Controller Bus Board	J2 on front of Disc Controller H/S DMA Board
P/N 900961 Bus Ribbon (Cable)	P2 on Formatter Bus Board	J3 on front of Disc Controller Bus Board
P/N 900960 Formatter Jumper Ribbon (Cable)	P2 on Formatter Radial Board	P2 on Formatter Processor Board

Central Cabinet Assembly Internal Cables

Check that the following cables are correctly routed, and properly connected and seated.

Cable	From	To
P/N 900042 Printer Cable	P3 on Printer Controller on left end of front of CPU Chassis	Back of I/O Panel
P/N 900901 VDT Cable(s)	J0 through J7 on VDT Controller on left side of front of CPU Chassis	Back of I/O Panel
P/N 901662 Control Panel Ribbon (Cable)	J2 of CPU Board	J1 on Control Panel
Power On Leads	Power Supply Harness	Power Switch on Control Panel

Disc Drive Cabling

Disc Bus Cabling

The Disc Bus Cable (P/N 902017) originates at P3 on the Formatter Bus board and terminates at J03 of the first disc drive (see Figures 15 and 16).

NOTE

Connector is not keyed. Pin 1 is on the bottom.

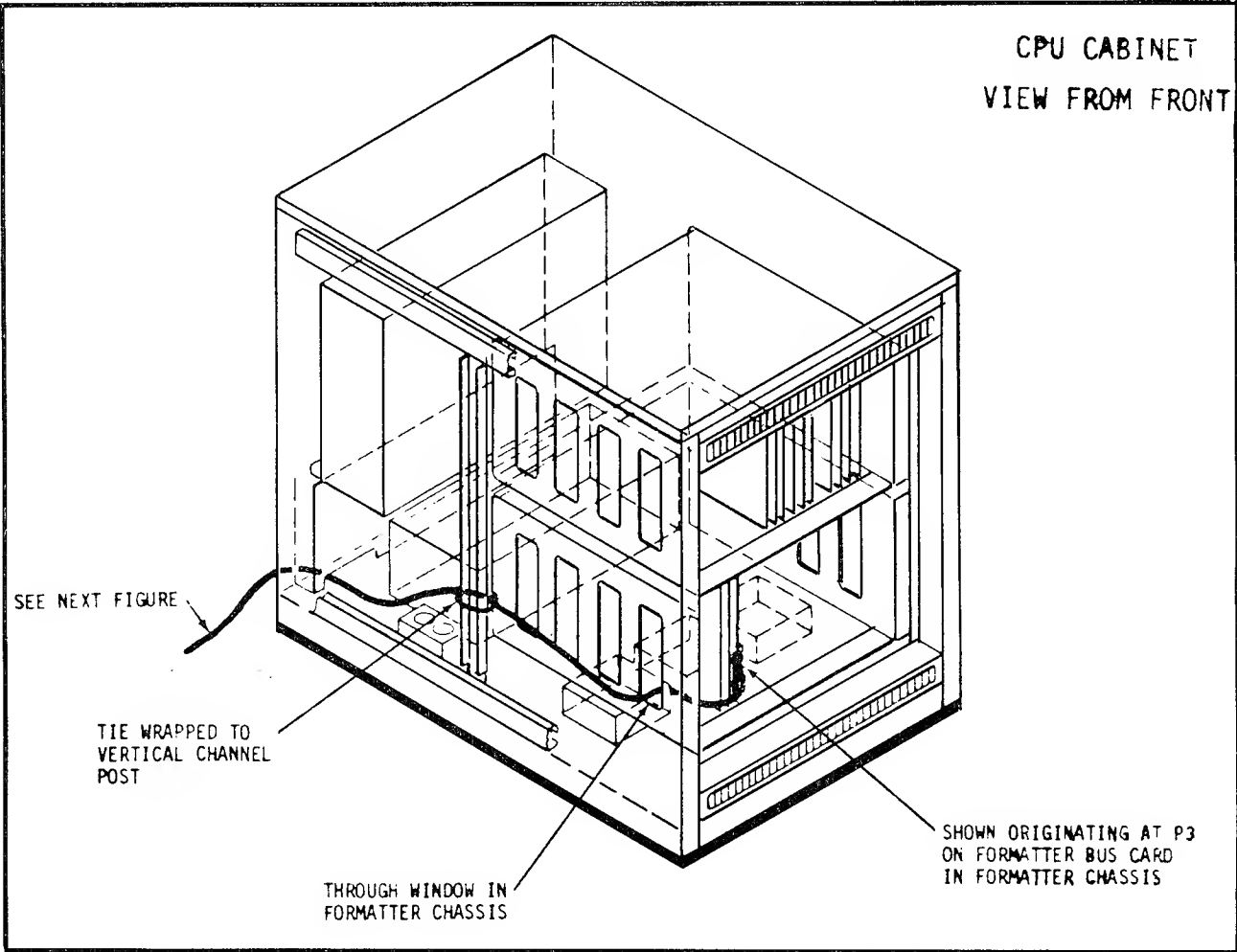

Figure 15. Disc Bus Cable Origination

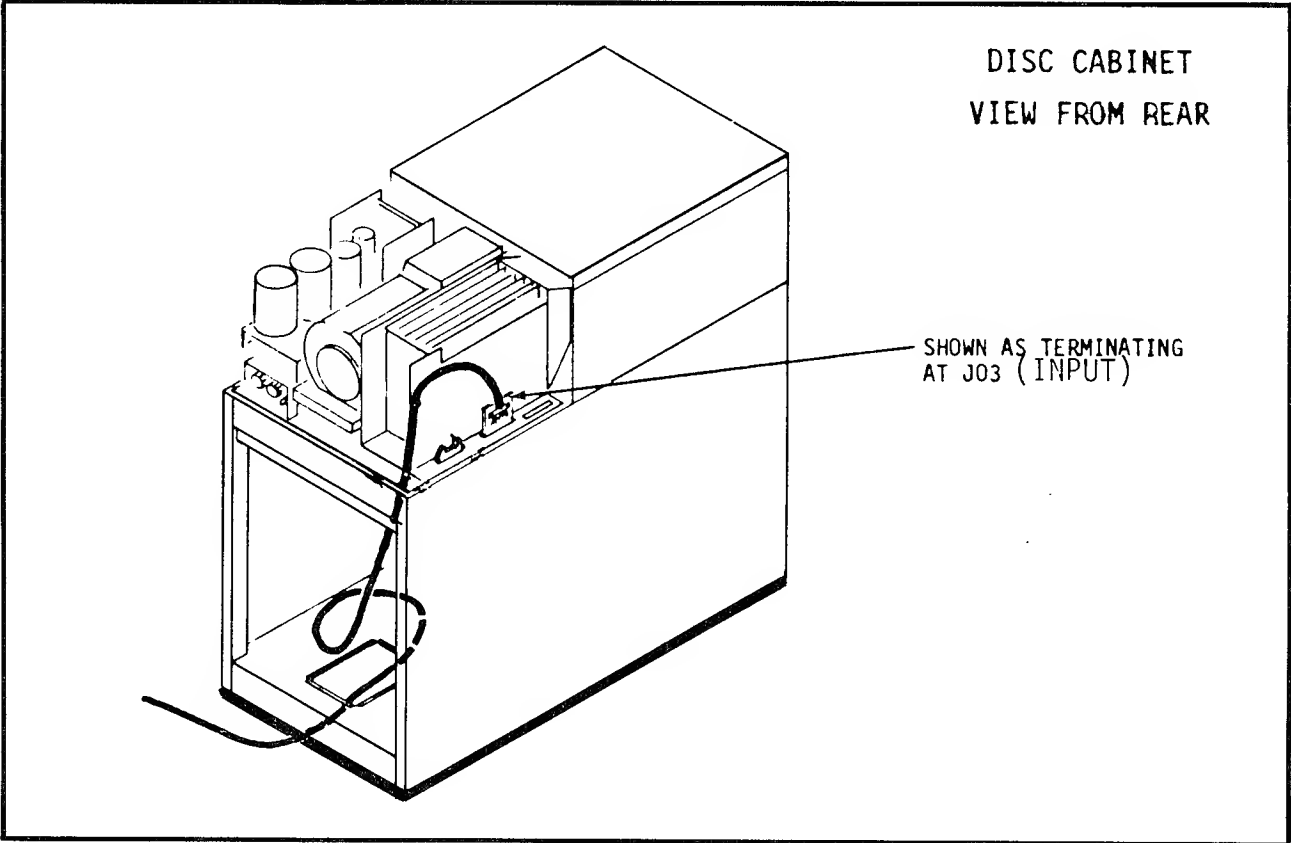

Figure 16. Disc Bus Cable Termination

If only one disc drive is to be installed on the system, a disc bus terminator (P/N 12321) must be inserted in J02.

The disc bus interconnect cable (P/N 902016) originates at J02 of the "from" disc drive, and terminates at J03 of the "to" disc drive (see Figures 17 and 18).

The last disc drive must have a disc bus terminator (P/N 12421) installed in J02.

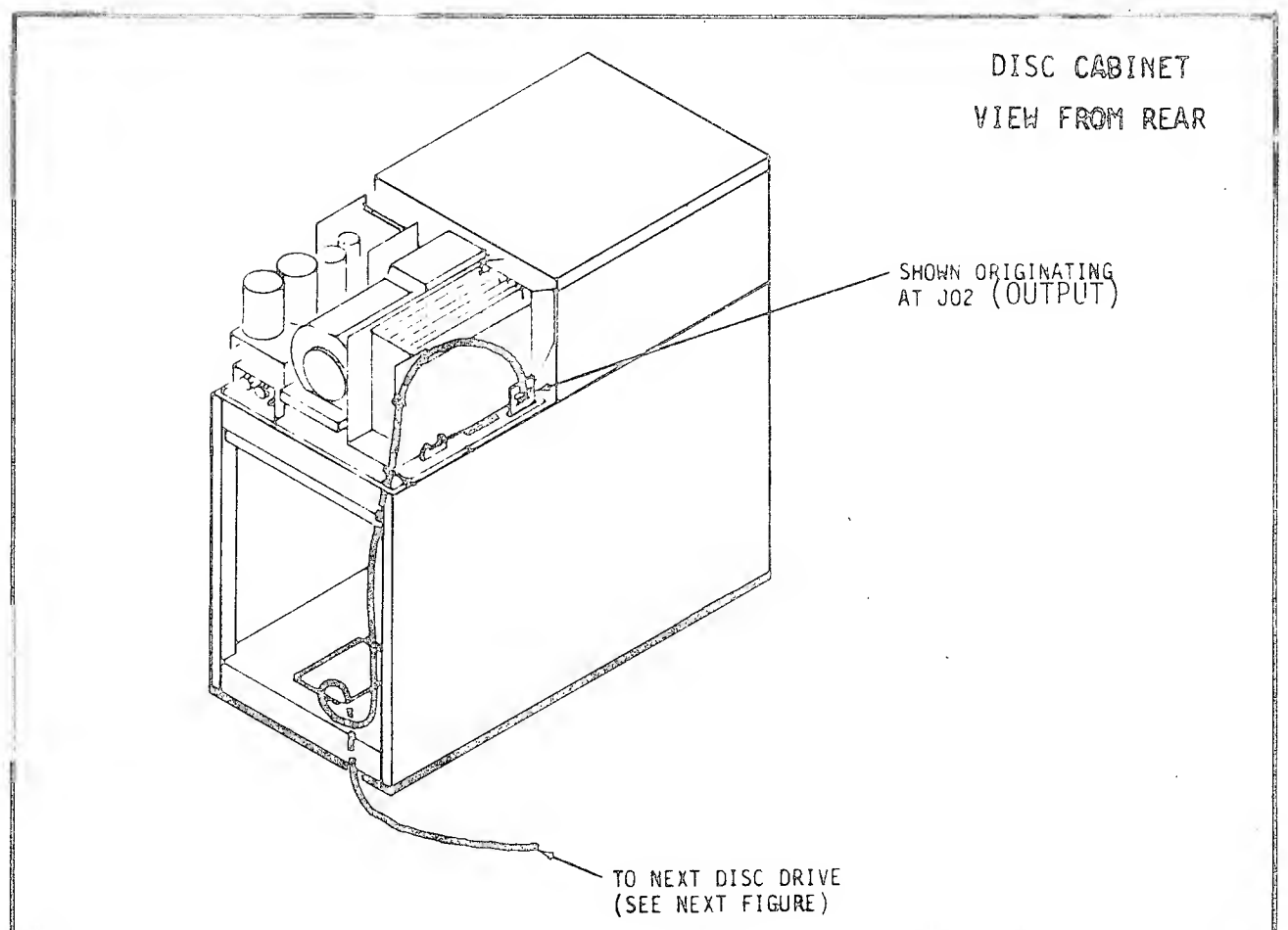

Figure 17. Disc Bus Interconnect Cable Origination

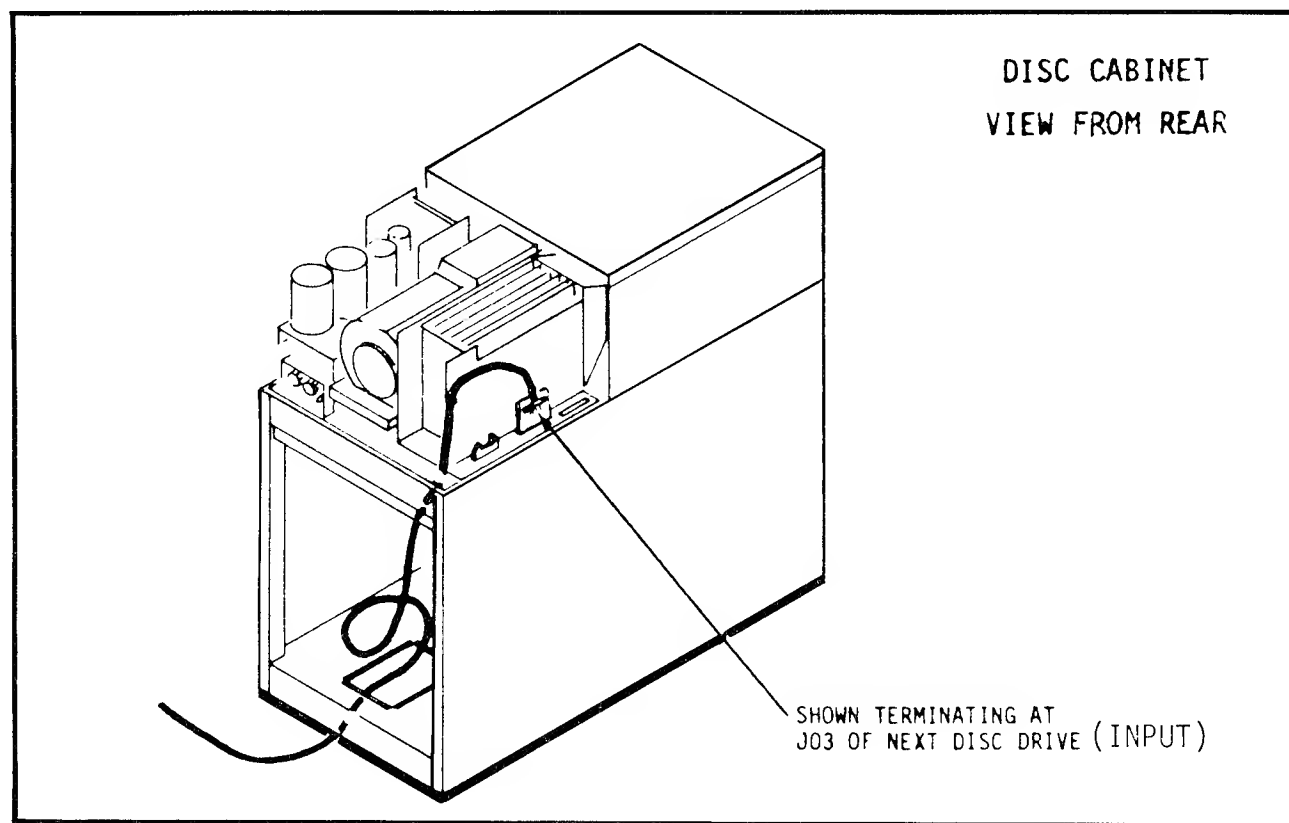

Figure 18. Disc Bus Interconnect Cable Termination

Disc Radial Cabling

A Disc Radial Cable (P/N 902015) connects each disc drive to the Central Cabinet Assembly. The Disc Radial Cable originates at jacks CH0 through CH3 on the rear of the formatter chassis, and terminates at J04 of the respective disc drive (see Figures 19 and 20).

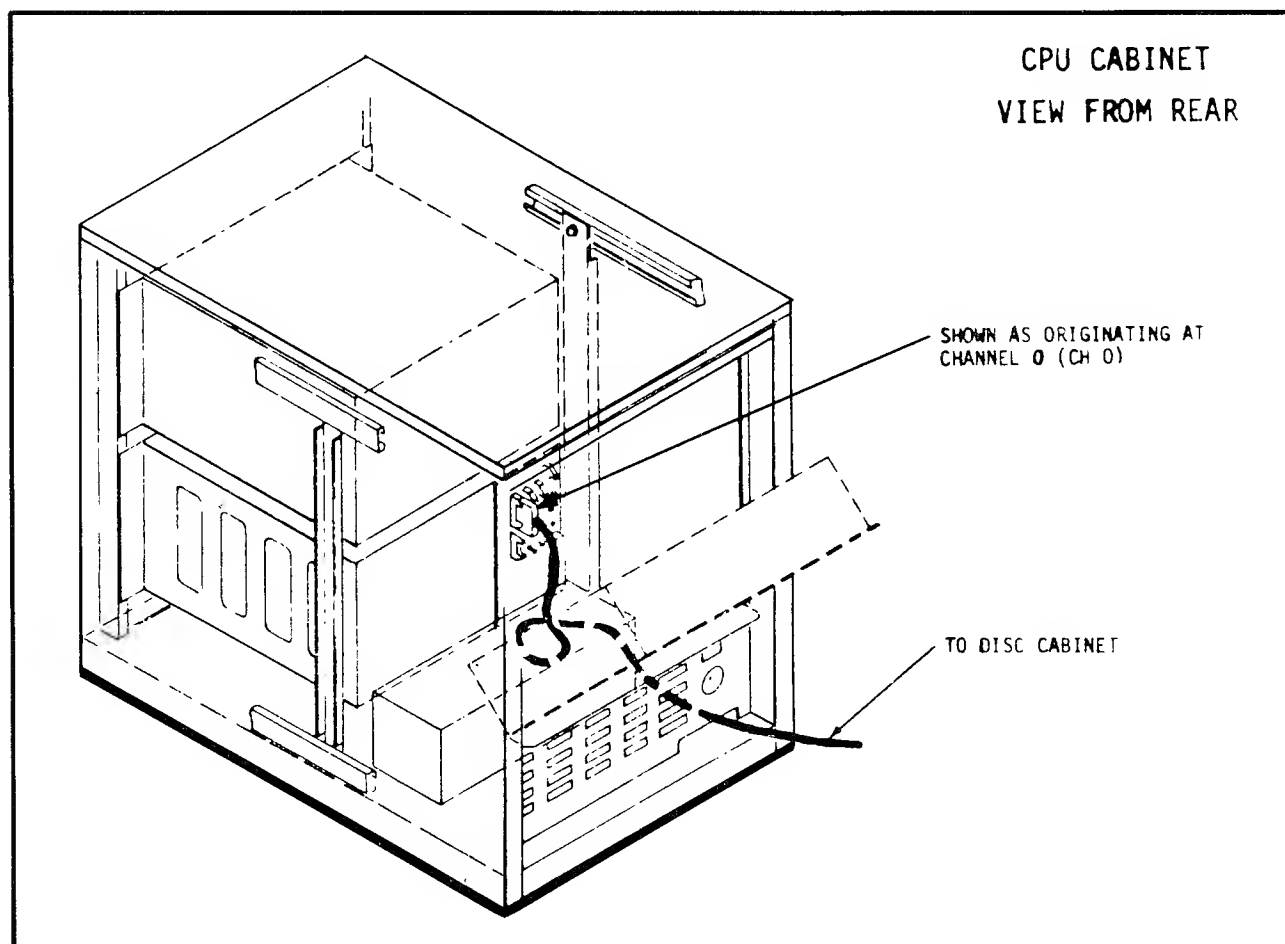

Figure 19. Disc Radial Cable Origination

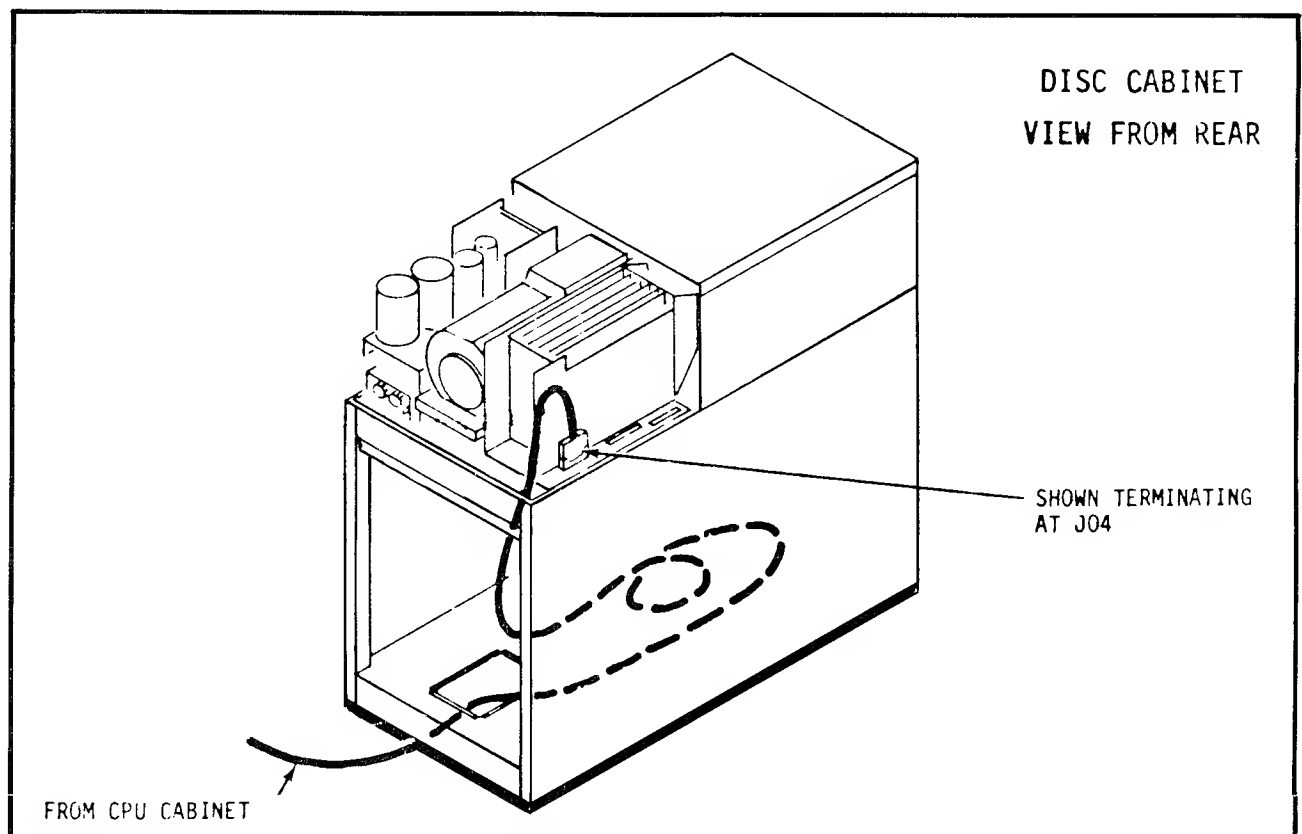

Figure 20. Disc Radial Cable Termination

NOTE

The end of the radial cable with the plug marked "CH0-3" is the end that attaches to the formatter chassis. The cable must not be reversed end-for-end.

VDT Cabling

The VDT signal cables (P/N 906041-001) originate at jacks CH0 through CH7 on the rear of the CPU cabinet. The cables terminate at the Main I/O jack on the respective VDT.

Connect the VDT power cable.

Printer Cabling

Refer to the respective printer service manual for the proper cabling connections.

Connect the printer power cable.

Magnetic Tape Cartridge Drive Cabling

The interface cabling for the Magnetic Tape Cartridge Drive is shown in Figure 21.

Place the drive on top of the Central Cabinet Assembly and route the interface cable through the rear of the cabinet over the upper card cage. Extract the Magnetic Tape Cartridge Drive Controller PCB and attach the interface cable to P2 ensuring that Pin 1 of the cable is aligned with Pin 1 of the connector P2. (Pin 1 is denoted by a ► symbol on the connector and a colored stripe on the cable.) Firmly reinsert the Controller PCB in its proper slot in the card cage (see Figure 2).

Connect the Magnetic Tape Cartridge Drive power cable.

Additional Peripheral Device Cabling

If additional peripherals are to be connected to the system, refer to the respective service manuals for the correct cabling connections; e.g., magnetic tape drive, second printer.

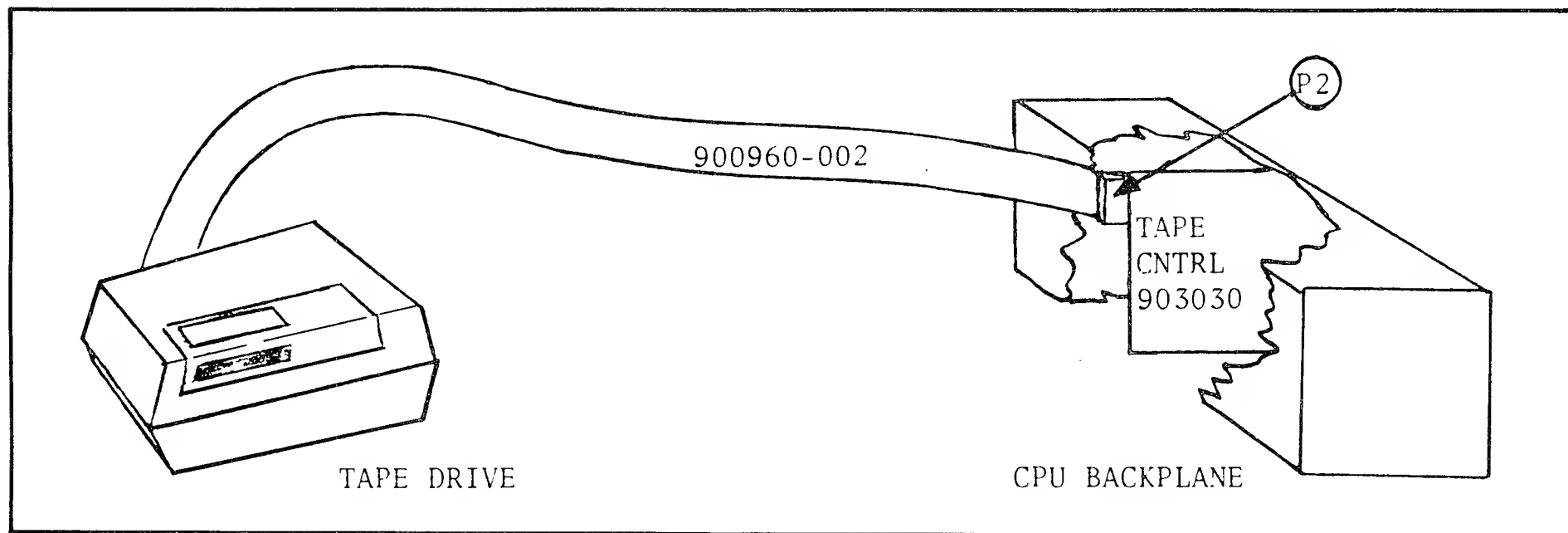

Figure 21. Magnetic Tape Cartridge Drive Cabling

Disc Drive Head Alignment Check

It is important to verify that the disc drive read/write heads have not been jarred out of alignment during shipping. Use the following procedure to verify alignment.

1. Using the TEST or Alternate Load option, load the program “:ALIGN” from the BOSS pack on drive 0.

NOTE

If the disc drive is severely misaligned, the program will not load. Refer to Technical Service Information Bulletin TSIB 2580-107 and use the manually loaded machine level program.

2. Remove the BOSS pack and insert the alignment pack on drive 0. Allow thirty minutes for the alignment pack to stabilize at operating temperature.

3. Set up oscilloscope as follows:

Channel 1:	AC 50 mv/cm
Channel 2:	AC 50 mv/cm
Sweep:	0.5 μ sec/cm
Sync:	CH1 INT POS
Mode:	ADD INVERT CH2

4. Connect Channel 1 to TP6 and Channel 2 to TP7 of the read/write matrix board (see Figure 22).

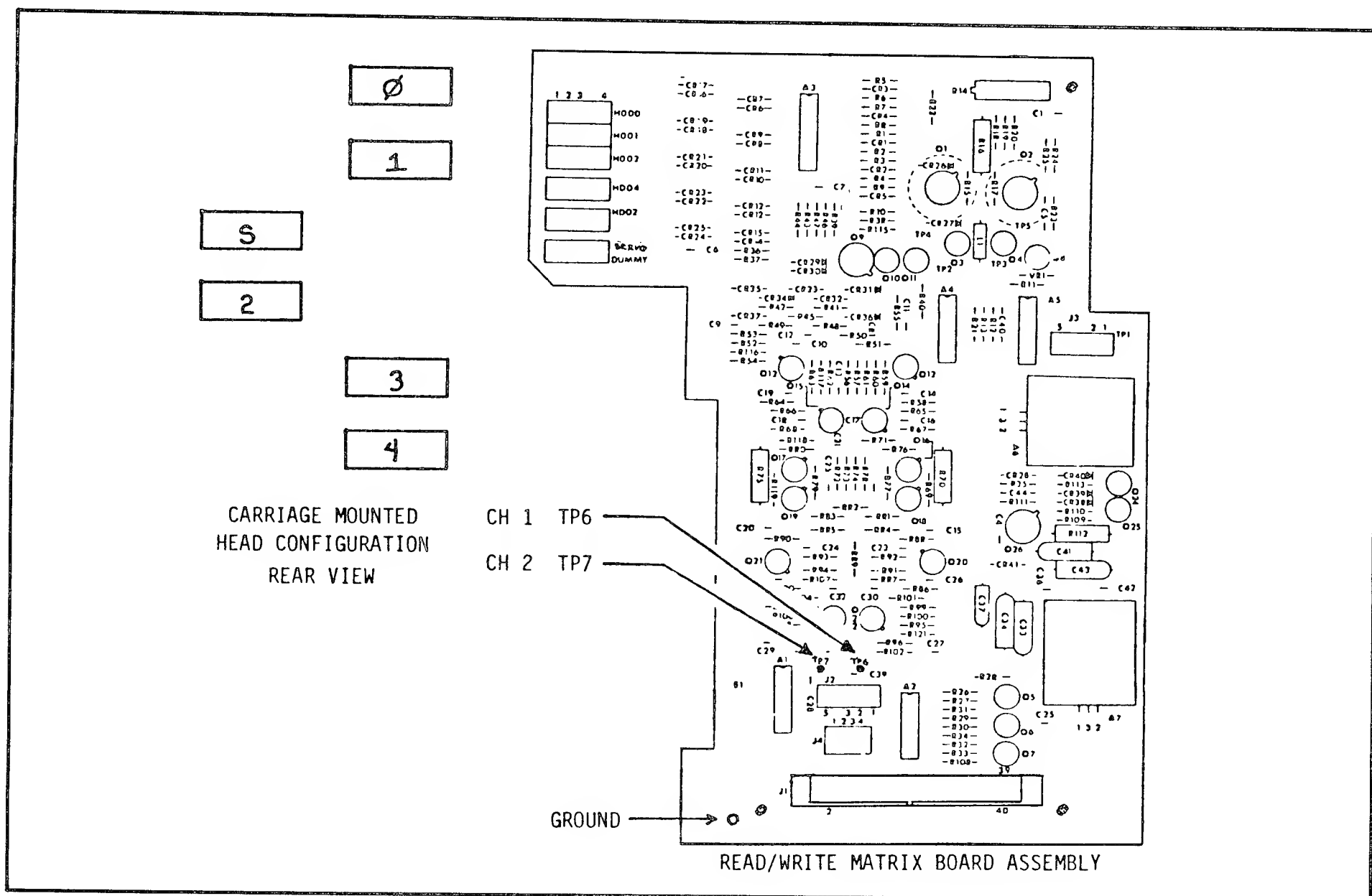

Figure 22. Head Alignment Test Points

5. Using program control, position the leads at the alignment cylinder 1F0₁₆ (496₁₀) and select head 0.
6. The Dibit Pattern shown in Figure 23 should now be displayed on the oscilloscope. Adjust scope sync if necessary. Correct alignment is indicated by the Amplitude "A" and the Amplitude "B" being equal.

NOTE

If Amplitude A and Amplitude B are not equal or if the indicated scope pattern cannot be obtained, refer to TSIB 2580-107 for the head alignment procedure.

7. Select the remaining heads and verify their alignment.
8. Repeat steps 3 through 7 for the remaining disc drive(s) in the system.

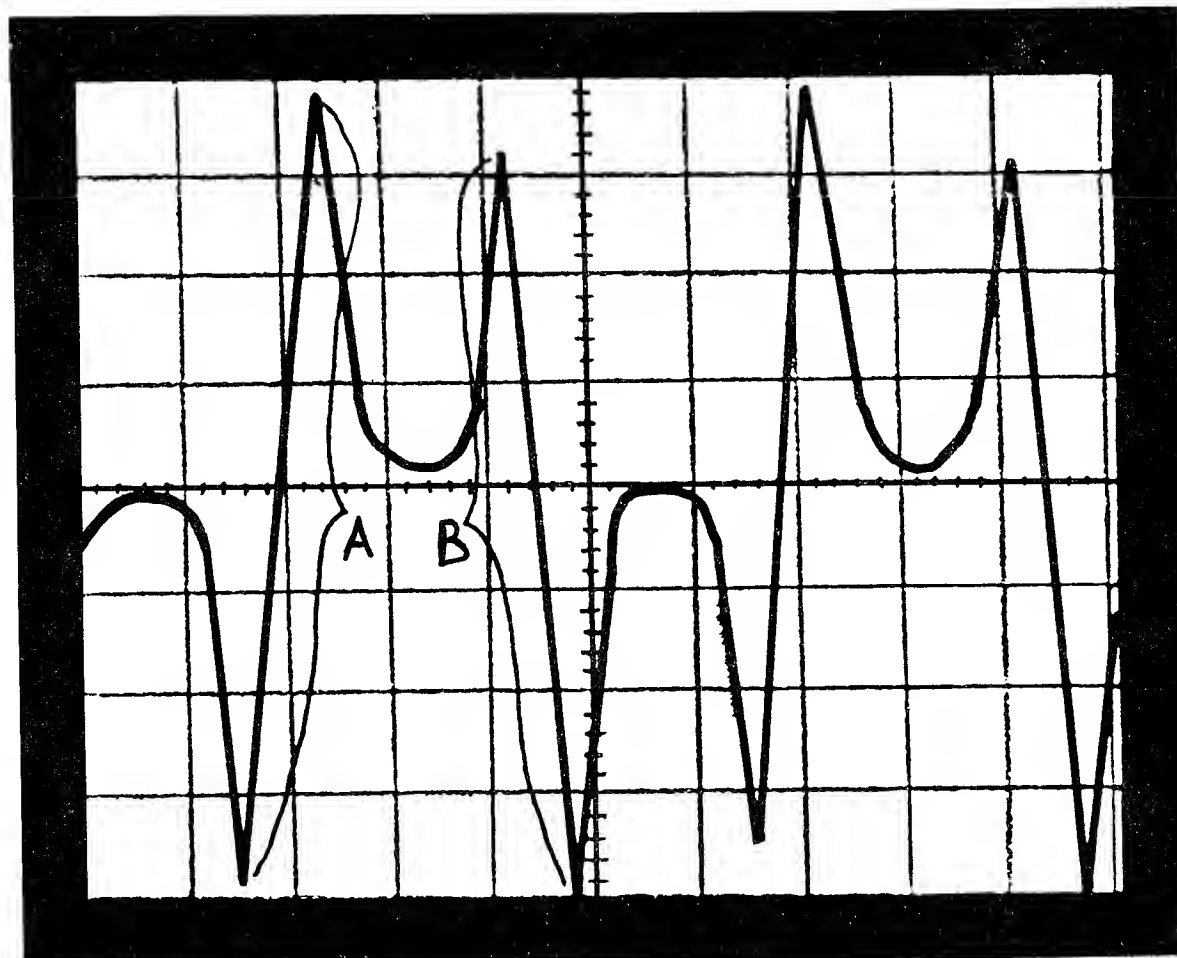

Figure 23. Ideal Dibit Pattern

System Operational Checks

This section describes the minimum checks to be performed. Detailed operating procedures are not included here. The respective service manuals mentioned should be referenced where applicable.

Recommended Bass Diagnostics

It is recommended that the BASS diagnostics listed below be run at the time of system installation to verify proper operation of the peripherals.

Name	Description
%M11	Tape Cartridge Drive Exerciser
%M12	Read Only Functional Verification Test
%D21	Long/Short Disc Seek Test
%D22	Disc Scan/Restore Test
%D23	Disc/DMA Write Verification Test
%D24	Direct File Disc Exerciser
%P01	Printer Quality Test
%P02	Printer Ripple Test
%P06	Printer Function – Burn-in Test
%P07	Printer Function Test
%V01	Keyboard Echo Test – Single VDT
%V02	Control Interaction Test – Single VDT
%V03	Terminal Exerciser – Multiple VDT
%V04	VDT Scrolling Test – Multiple VDT
%V05	VDT Print and Test – Multiple VDT
%V06	VDT Control Function Test – Multiple VDT

All BASS diagnostics except %M11 and %M12 (Tape Cartridge Diagnostics) are selected as follows:

1. Set CPU sense switches for Disc System Load.
2. Press and release Processor LOAD switch.
3. Type "N" in response to "DO YOU WANT SPOOLING?"
4. Type "RUN BASS" in response to "READY".
5. Enter date and time as requested.
6. Select B/4 SERVICE SYSTEM.
7. Select the BASS programs listed, except %M11 and %M12.
8. Enable and reset error file as requested by diagnostic. At the completion of all selected BASS diagnostics, the error file will be displayed.

Tape Cartridge diagnostics %M11 are selected as follows:

1. Set CPU sense switches for Disc Alternate Load.
2. Insert scratch tape media into tape drive.
3. Press and release Processor LOAD switch.
4. The VDT will display "MAKE ENTRY TO OVERRIDE DEFAULT" within 10 seconds, press the VDT space bar.
5. Type "BBIITC" followed by "CR" (carriage return) key in response to "ENTER PROGRAM NAME".
6. Type "BASS" in response to "ENTER PROGRAM NAME (*MTC or BASS)".
7. Enter the date and time as requested.
8. Select B/4 SERVICE SYSTEM.
9. Select %M11 and %M12.
10. Enable and reset error file as requested by diagnostic. At the completion of the diagnostics the error file will be displayed.